

Our associates will ensure the tool works properly before you leave the store. If you experience issues with the tool while completing your project, simply bring it back to the Tool Rental Center to get a replacement. If you purchase Damage Protection at the time of your rental, you are not responsible for repair costs for tools that break due to normal use.





MBH2W2015A.1

MODELS:
BH2W2015GX

ITEM NUMBER:
SERIAL NUMBER: _____

Owner's Manual

Instructions for Assembly, Testing, Operation, Servicing & Storage

Log Splitter: Outdoor hydraulic powered machine that splits wood logs.

WARNING

READ and UNDERSTAND this manual completely before using log splitter.

All operators of this equipment must read and completely understand all safety information, operating instructions, maintenance and storage instructions. Failure to properly operate and maintain the log splitter could result in serious injury to the operator or bystanders from moving parts that can crush or cut, flying objects, burns, fire or explosion, escaping high pressure hydraulic fluid, or carbon monoxide poisoning. In particular, be aware of the following hazards:

Crush and Cut Hazards

Moving parts can crush and cut hands and fingers. Keep hands clear of endplates, wedge, and logs while splitting.

High Pressure Hydraulic Fluid Hazards

High fluid pressures and temperatures are developed in hydraulic log splitters. Hydraulic fluid escaping through even a pin-size hole opening can puncture skin and cause severe blood poisoning. Inspect hydraulic system regularly for possible leaks. Never check for leaks with your hand while the system is pressurized. Seek medical attention immediately if injured by escaping fluid.

Fire Hazards

- If your log splitter is intended for use near any ignitable forest, brush, or grassy covered land, the engine exhaust should be equipped with a spark arrestor.
- Keep a fire extinguisher with you, rated for ordinary combustibles and flammable liquids.

STOP!

ASSEMBLY REQUIRED: This product requires assembly before use. See "Assembly" section for instructions.

INSPECT COMPONENTS. Closely inspect upon receipt to make sure no components are missing or damaged. See "Assembly" section for instructions on whom to contact to report missing or damaged parts.

ADD ENGINE OIL and HYDRAULIC OIL BEFORE USING: This product is shipped without engine oil or hydraulic oil. DO NOT start log splitter before adding both oils. See "Assembly" and "Initial Unpacking & Set-up" sections for detailed instructions.

PRIME THE PUMP BEFORE USE: The pump on this product needs to be primed before use. See Initial Setup for instructions.

Any Questions, Comments, Problems or Parts Orders

Call Iron & Oak Product Support 1-800-817-1005

Hazard Signal Word Definitions





	<p>This is the safety alert symbol. It is used to alert you to potential personal injury hazards. Obey all safety messages that follow this symbol to avoid possible injury or death.</p>
	<p>DANGER (red) indicates an imminently hazardous situation which, if not avoided, will result in death or serious injury.</p>
	<p>WARNING (orange) indicates a potentially hazardous situation which, if not avoided, could result in death or serious injury.</p>
	<p>CAUTION (yellow) indicates a potentially hazardous situation which, if not avoided, may result in minor or moderate injury.</p>
	<p>CAUTION (yellow) used without the safety alert symbol indicates a potentially hazardous situation which, if not avoided, may result in property damage.</p>

fig01453

Table of Contents

About Your Log Splitter..... 4

Safety Label Locations 5

Machine Components Identification 7

Initial Set-up 8

Moving & Towing to the Job Site 10

Before Each Use:

 Step One: Inspection/Maintenance..... 13

 Step Two: Fueling 16

 Step Three: Work site Selection & Set-up..... 17

Splitting Operation 18

Specifications..... 27

Summary of Important Safety Information for Operation..... 30

About Your Log Splitter

Thank you for purchasing your Iron & Oak log splitter!

About Your Log Splitter

This log splitter is a machine designed to split wood logs using a hydraulically powered moving wedge. The gasoline-powered engine is used to pressurize the system.

This log splitter model is capable of splitting logs up to 24" long and 16" in diameter

This log splitter is designed to split logs *lengthwise with the grain only*.

This log splitter model is designed with a *unique, timesaving feature* -- a double-edged cutting wedge that is capable of splitting wood on both the extension and retraction strokes of the wedge.

The technical specifications for your log splitter are provided in the "Specifications" section of this manual.

WARNING

This log splitter uses a high-pressure hydraulic system to generate a very strong splitting force. **Read the manual completely** before using the machine to understand how to safely operate and maintain it.

Follow all safety precautions presented throughout this manual. A summary of important safety information can be found at the end of the manual.

Contact Iron & Oak Product Support at 1-800-817-1005 for any questions about the appropriate use of this log splitter and/or optional accessories.

Attention: All Rental Companies and Private Owners who loan this equipment to others!

All persons to whom you rent/loan the log splitter must have access to and read this manual. Keep this owner's manual with the splitter at all times and advise all persons who will operate the machine to read it. You must also provide personal instruction on how to safely operate the splitter and be available to answer any questions a renter/borrower might have.

Safety Label Location

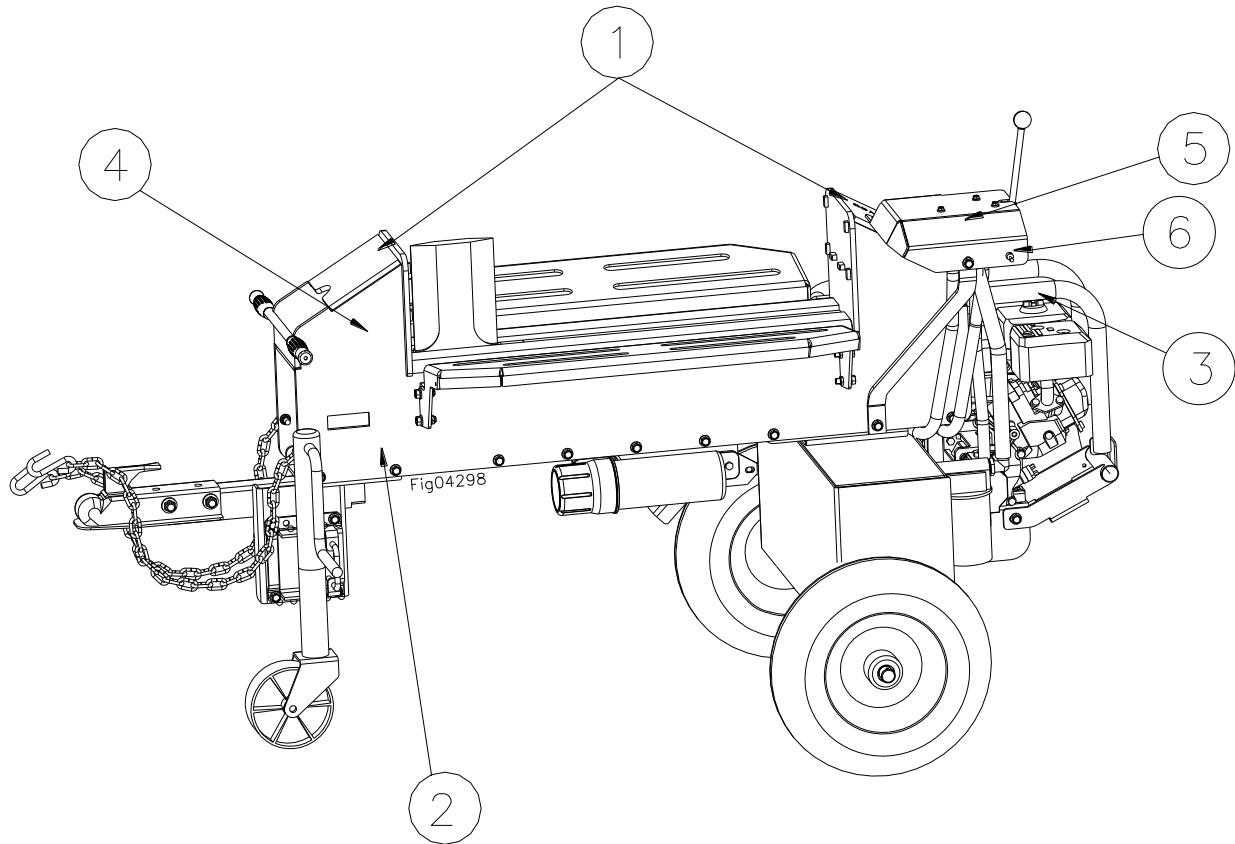

Ref#	Part #	Description	QTY
1	787944	Pinch Point Decal	2
2	780187	Moving/Towing Decal	1
3	786635	Burn Hazard Warning	1
4	787948	45 MPH Decal	1
5	787753	Splitter Warning / Instructions Decal	1
6	793326	Kill Switch Decal	1

Always make sure safety labels are in place and in good condition. If a safety label is missing or not legible, order new labels or unsafe operation could result.

Safety Label Location

1

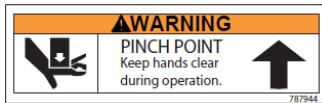

2

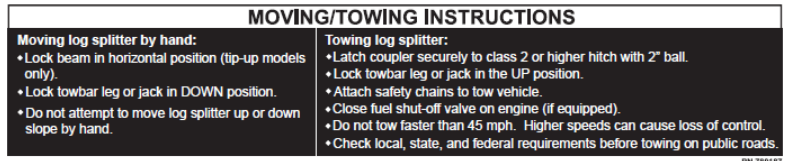

3



4



5

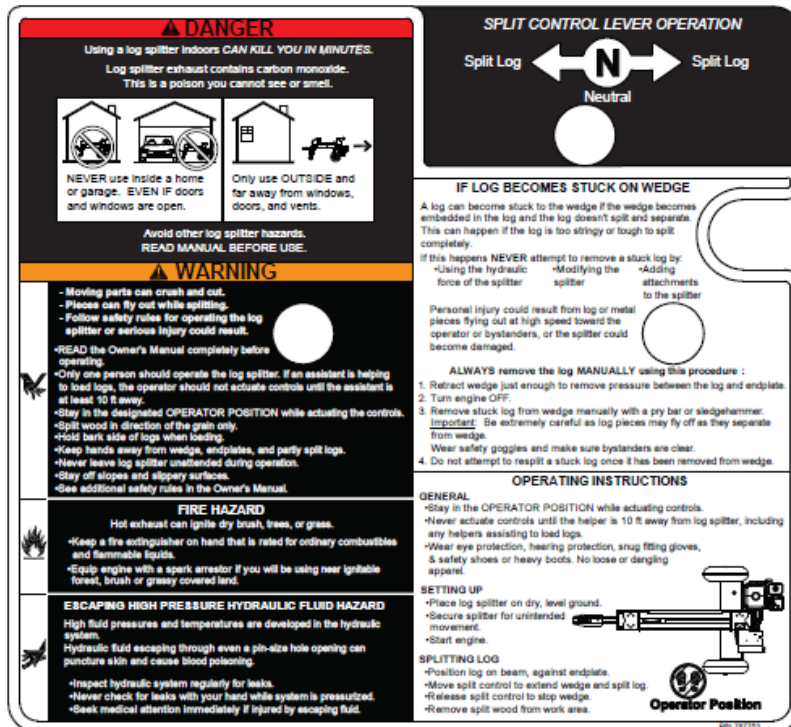

6

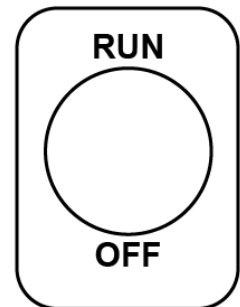

Machine Component Identification

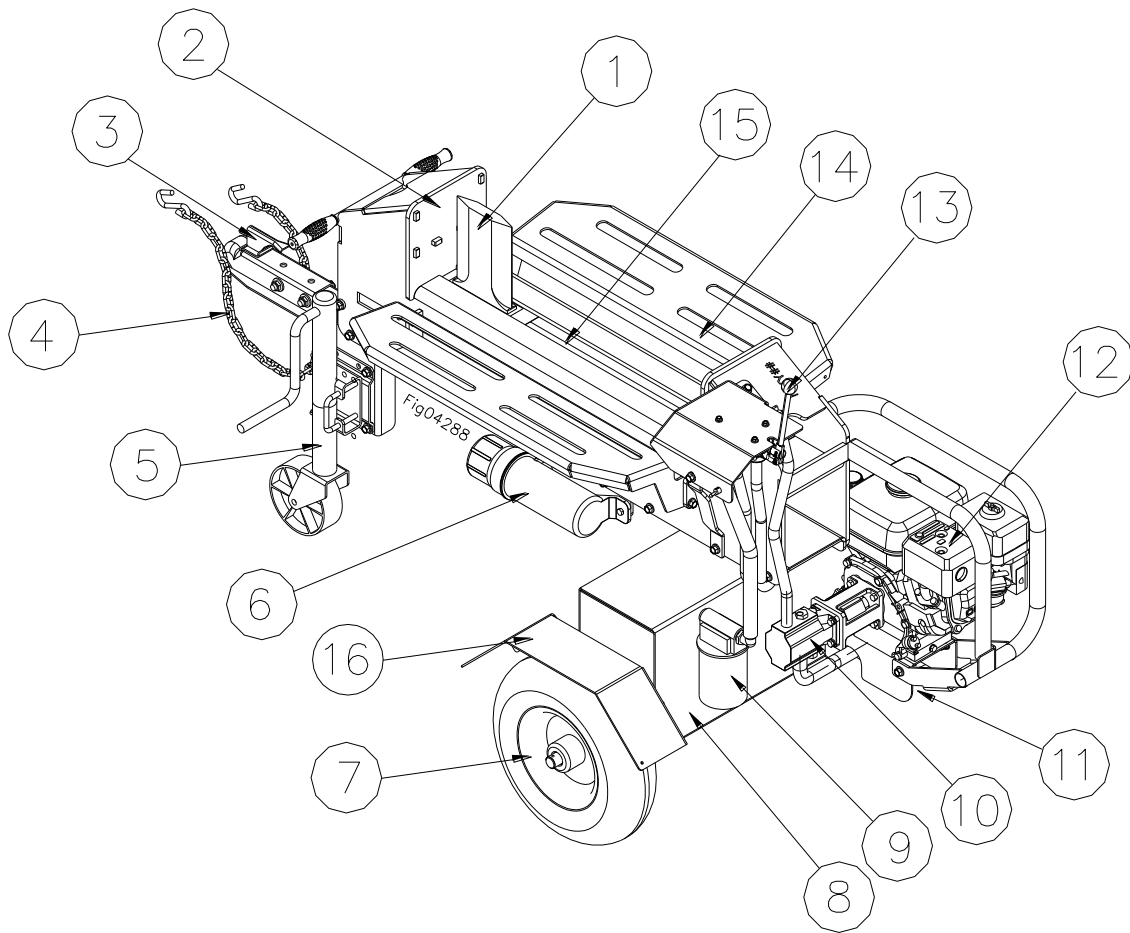

Ref #	Description
1	Wedge
2	End Plate
3	2" Ball Coupler
4	Safety Chains
5	Jack
6	Manual Tube
7	Tires
8	Hydraulic Tank

Ref#	Description
9	Return Line Hydraulic Fluid Filter
10	Hydraulic Pump
11	Suction Strainer (hidden)
12	Engine
13	Splitter Control Lever
14	Log Table
15	Beam/Cylinder
16	Fender

Initial Set-up

⚠ WARNING

Carefully read and follow all instructions for initial assembly and set-up of this log splitter.

Failure to properly assemble and set up this equipment could result in serious injury to the user or bystanders, or cause equipment damage.

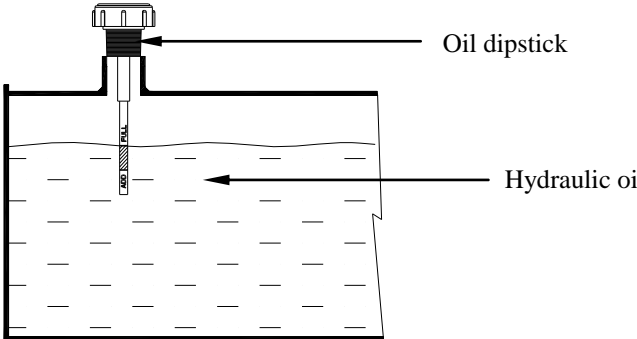
<p>Step One: Assemble log splitter</p>	<p>Assemble your log splitter. See the “Assembly” section of this manual – It will provide you with detailed instructions on:</p> <ul style="list-style-type: none"> • Inspecting shipped components and whom to contact if anything is missing or damaged. • Assembly. • Testing.
<p>Step Two: Add oil to engine</p>	<p>Add oil to engine. Using a funnel, add SAE 10W-30 oil up to the FULL mark on the dipstick. (See engine Owner’s Manual for oil capacity and location of fill cap.)</p>
<p>Step Three: Add Hydraulic Oil to Reservoir</p>	<ol style="list-style-type: none"> 1. Remove hydraulic oil dipstick. 2. Refer to the Specifications section for approximate hydraulic oil capacity. 3. Fill reservoir with 10 wt AW32, ASLE H-150, or ISO 32 oil. Use a funnel 4. Replace hydraulic oil dipstick and check that oil level reads full. Note: Do not thread in dipstick when checking oil level. 5. Disconnect the spark plug wire from the spark plug 6. Pull on the starter grip recoil at least 20 times so that hydraulic fluid has cycled through the pump 7. Reconnect the spark plug wire to the spark plug 8. Start engine and use split control lever to extend and retract wedge 5 (five) times to remove air from the high pressure lines. 9. With wedge retracted, check oil level again. Fill if necessary. <div style="text-align: center;">  </div> <p>Note: If the log splitter will be run for long periods of time in outdoor temperatures above 70°F, we recommend changing the hydraulic oil to DEXTRON III.</p>

Initial Set-up

Step Four: Check Hydraulic system

Check the hydraulic system carefully:

1. Visually inspect all hoses, tubing, clamps/fittings, pump, and cylinder for cracks, fraying, kinks, or other damage.
2. Check all components for oily residue, which may indicate a leak.

Do NOT operate the log splitter if there is any indication of damage or oily residue. Small leaks in hydraulic lines can cause severe injuries and can also be an indication of catastrophic failure in the near future. The life of hydraulic hoses may be from a few months to a few years, depending on use and storage patterns.

⚠ WARNING: High fluid pressures and temperatures are developed in hydraulic log splitters. Hydraulic fluid escaping through a pin hole sized opening can burn or puncture skin, resulting in wounds that could cause blood poisoning, infection, disability, gangrene, amputation, or death. Therefore, the following instructions should be heeded at all times when inspecting or servicing the hydraulic components of the log splitter:

- Stop the engine, disconnect the spark plug, and move the split control lever back and forth to relieve pressure before changing or adjusting hydraulic system components such as hoses, tubing, fittings or other components.
- NEVER check for leaks with your hand. Leaks can be located by holding a piece of cardboard or wood (at least two feet long) with your hand at one end and passing the other end over the suspected area (wear eye protection). Look for discoloration of the cardboard or wood.
- NEVER adjust the pressure setting of the pump or valve.
- If injured by escaping fluid, no matter how small the wound is, see a doctor immediately. A typical injection injury may be a small puncture wound that does not look serious. However, severe infection or reaction can result if proper medical treatment is not administered immediately by a doctor who is familiar with injection injuries.

⚠ WARNING: NEVER remove the hydraulic oil fill cap when the engine is running or hot. Hot oil can escape causing severe burns. Allow log splitter to cool completely before removing hydraulic oil fill cap.

Moving & Towing to Job Site

WARNING

The log splitter is heavy. It can crush and cause serious injury if it rolls out of control or tips over. Follow the instructions below for safely moving and towing the log splitter.

Moving the log splitter

1. Engine Off	IMPORTANT: Make sure log splitter engine is off. Never move the log splitter with its engine running.
2. Fuel Valve Off	Turn fuel valve off to prevent carburetor flooding and reduce the chance of fuel leakage.
3. Move Log Splitter to Work Site or Tow Hitch	Roll the splitter by hand either directly to chosen work site or to vehicle hitch for towing. (See instructions on p. 17 on selecting a work site.) <u>Important Safety Instructions:</u> <ul style="list-style-type: none"> • Hills. Do not move the log splitter up or down hills by hand -- use a towing vehicle. • No riding. Never allow anyone to sit or ride on the log splitter. • No cargo. Never transport cargo or wood on the log splitter.

Towing:

1. Read Instructions	Review towing safety instructions in your vehicle manual.
2. Check Tires	Make sure tires are fully inflated and in good operating condition. See tire sidewall for recommended tire pressure.  WARNING: <ul style="list-style-type: none"> • Do not over-inflate tires. Serious injury can occur if tire explodes. • When seating a bead after repair, do not exceed 30 PSI. Pressures higher than 30 PSI can cause the tire and wheel to rupture and explode.
3. Turn Engine Off	Turn engine off. Never move the log splitter with the engine running.
4. Turn Fuel Valve Off	Turn fuel valve off. This will prevent carburetor flooding and reduce the chance of fuel leakage.

Moving & Towing to Job Site

5. Attach to hitch (2" ball)

Attach log splitter to vehicle hitch

1. Attach log splitter's coupler to a class 2 or higher hitch with 2" ball (only).
2. Adjust coupler to ball by raising locking lever and turning lock nut with fingers.
3. Proper adjustment is obtained when coupler is as tight as possible on ball and locking lever can still be opened and closed.
4. Lock lever closed to secure the attachment. An optional locking pin or padlock may be inserted in the locking lever hole for extra security.

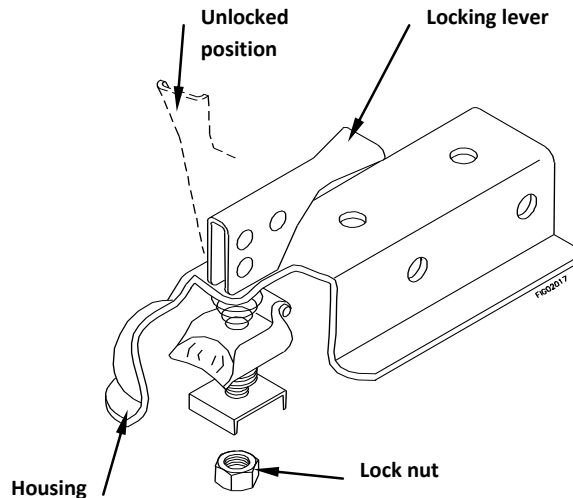

5. Attach Safety Chains

Attach safety chains.

1. Two safety chains must be used while towing.
2. Cross safety chains under the coupler allowing only enough slack for vehicle turns.

6. Put Jack and Towbar Leg Up

To provide adequate ground clearance while towing, secure both the jack and tow bar leg in the "UP" position.

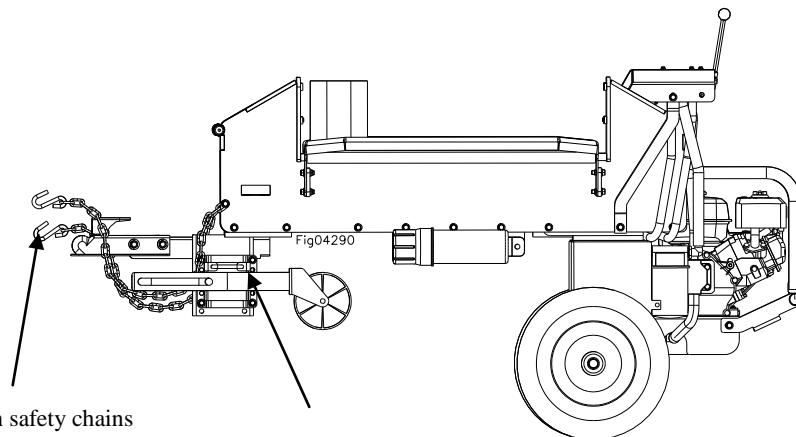

Hook both safety chains to the towing vehicle

Pull latch and swing jack to the "up" position

Moving & Towing to Job Site

<p>7. Tow to Desired Location</p>	<p>Tow log splitter carefully to desired work site. (See instructions on pg.17 on selecting an appropriate work site.)</p> <p><u>Important safety instructions:</u></p> <ul style="list-style-type: none">• Added length. Be aware of the added length of the splitter.• Speed limit. Never tow this log splitter over 45 mph. Faster speeds may result in loss of control.• Rough terrain. Drive slowly and take extra caution when traveling over rough terrain.• On public roads. If towing on a public road, make sure to comply with all local, state, and federal towing requirements. It is the sole responsibility of the purchaser to obtain licensing, trailer lights, safety chains or signage, as needed to comply.• Unattended. Turn off the towing vehicle before leaving the splitter unattended. <p>Under the influence. Never tow or operate this splitter while under the influence of alcohol, drugs, or medication.</p>
<p>8. Lower Jack Down & Unhitch</p>	<p>Lower the jack down and then unhitch from vehicle. NEVER operate log splitter while it is attached to the vehicle.</p> <ol style="list-style-type: none">1. Lower the jack and use it to lift the coupler slightly to assist in unhitching.2. Unhitch from vehicle.

Before Each Use – Inspection / Maintenance

Step One: Inspect and maintain log splitter before each use.

If the log splitter has been used previously, it must be inspected and maintained BEFORE EACH SUBSEQUENT USE.

WARNING

ALWAYS shut off the engine, disconnect the spark plug, and relieve system pressure before inspecting, cleaning, adjusting, or repairing the splitter. Relieve system pressure by moving the split control lever back and forth several times.

Important:

If a part needs replacement, only use parts that meet the manufacturer’s specifications. Replacement parts that do not meet specifications may result in a safety hazard or poor operation of the log splitter.

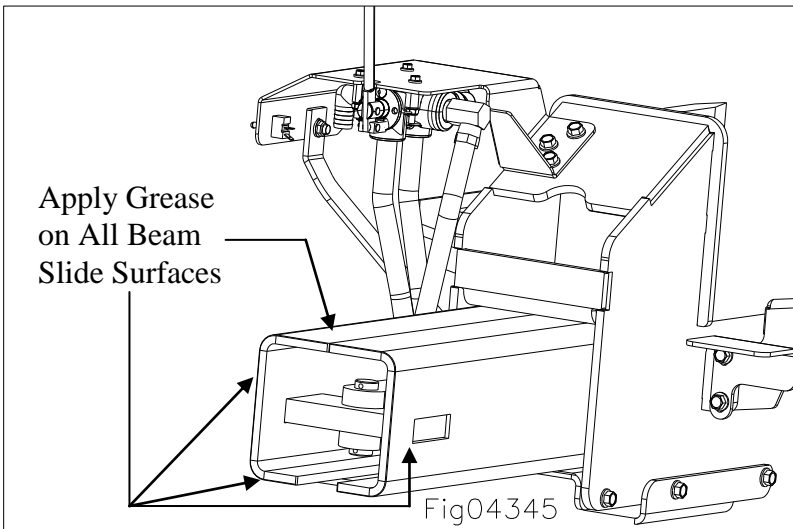
1. Engine off / relieve hydraulic pressure	<p>Perform all inspections/repairs with the engine off and hydraulic system pressure relieved.</p> <ol style="list-style-type: none"> 1. Make sure engine is off and cool. 2. Disconnect the spark plug 3. Relieve all hydraulic system pressure by moving the split control lever back and forth several times.
2. Remove debris	<p>Remove debris from engine, muffler, and moving parts.</p> <ol style="list-style-type: none"> 1. <u>Engine debris.</u> Debris on a hot engine can be a fire hazard. Clean debris and chaff from engine cylinder head, cylinder head fins, blower housing rotating screen, and muffler areas. Avoid contact with hot muffler. 2. <u>Other debris.</u> Debris on moving parts can cause excess wear. Clear debris from the beam, wedge, and end plates.
3. Fuel tank / lines	<p>Check fuel tank and fuel lines for leaks.</p> <p>Any fuel leak is a fire hazard. Fix any fuel leaks before starting engine.</p>
4. Mechanical parts	<p>Check to be sure all nuts and bolts are tight to make sure the log splitter is in safe working condition.</p> <p>Extend wedge slide, and apply grease.</p> <div style="text-align: center; margin-top: 10px;">  </div>

Before Each Use – Inspection / Maintenance

5. Hydraulic system	<p>Check the hydraulic system carefully:</p> <ol style="list-style-type: none"> 1. Visually inspect all hoses, tubing, clamps/fittings, pump, and cylinder for cracks, fraying, kinks, or other damage. 2. Check all components for oily residue, which may indicate a leak. <p>Do NOT operate the log splitter if there is any indication of damage or oily residue. Small leaks in hydraulic lines can cause severe injuries and can also be an indication of catastrophic failure in the near future. The life of hydraulic hoses may be from a few months to a few years, depending on use and storage patterns.</p> <p>⚠️WARNING: High fluid pressures and temperatures are developed in hydraulic log splitters. Hydraulic fluid escaping through a pin hole sized opening can burn or puncture skin, resulting in wounds that could cause blood poisoning, infection, disability, gangrene, amputation, or death. Therefore, the following instructions should be heeded at all times when inspecting or servicing the hydraulic components of the log splitter:</p> <ul style="list-style-type: none"> • Stop the engine, disconnect the spark plug, and move the split control lever back and forth to relieve pressure before changing or adjusting hydraulic system components such as hoses, tubing, fittings or other components. • NEVER check for leaks with your hand. Leaks can be located by holding a piece of cardboard or wood (at least two feet long) with your hand at one end and passing the other end over the suspected area (wear eye protection). Look for discoloration of the cardboard or wood. • NEVER adjust the pressure setting of the pump or valve. • If injured by escaping fluid, no matter how small the wound is, see a doctor immediately. A typical injection injury may be a small puncture wound that does not look serious. However, severe infection or reaction can result if proper medical treatment is not administered immediately by a doctor who is familiar with injection injuries.
6. Hydraulic oil level	<p>Check dipstick to make sure hydraulic oil level is to the fill line with cylinder retracted. Fill as needed. Note: Do not thread in the oil dipstick when checking hydraulic oil level.</p> <p><u>Note:</u> Fill the tank with 10 wt AW32, ASLE H-150, or ISO 32 hydraulic oil. If the log splitter will be run for long periods of time in outdoor temperatures above 70°F, we recommend changing the hydraulic oil to DEXTRON III.</p> <p>⚠️WARNING: NEVER remove the hydraulic oil fill cap when the engine is running or hot. Hot oil can escape causing severe burns. Allow log splitter to cool completely before removing hydraulic oil fill cap.</p>
7. Engine	<p>Inspect and perform engine maintenance as directed in the engine manual.</p>
8. Spark arrestor muffler	<p>If the engine is equipped with a spark arrestor muffler, clean and inspect it regularly (follow spark arrestor manufacturer’s service instructions). Replace if damaged.</p>
9. Tires	<p>Make sure tires are fully inflated and in good repair if you will be towing the splitter.</p> <p>See tire sidewall for recommended tire pressure.</p>

Before Each Use – Inspection / Maintenance

⚠ WARNING:

- Do not over-inflate tires. Serious injury can occur if tire explodes.
- When seating a bead after repair, do not exceed 30 PSI. Pressures higher than 30 PSI can cause the tire and wheel to rupture and explode.

10. Shields / guards



Replace all guards and shields after servicing the log splitter.

Before Each Use – Fueling

Step Two: Fueling

WARNING

Gasoline is highly flammable and explosive. You can be burned or seriously injured when handling fuel. Use extreme care when handling gasoline.

1. Engine off / cool	<p>The engine must be off and allowed to cool at least two minutes before adding fuel.</p> <p> WARNING: A running engine is hot enough to ignite fuel. Never add fuel or remove gas cap if engine is running or still hot.</p>
2. Outdoor location	<p>Fill fuel tank outdoors – never indoors.</p> <p> WARNING: Gasoline vapors can ignite if they collect inside an enclosure. Explosion can result.</p>
3. Remove gas cap	<p>Remove engine gas cap.</p>
4. Add gasoline	<p>Add gasoline through fill opening from an UL-approved container.</p> <p><u>Important Safety Instructions:</u></p> <ul style="list-style-type: none"> Use approved container. NEVER pump fuel directly into engine at gas station. Static charge can build and ignite fuel. Use a UL approved fuel container to transfer gas to the engine. Don't overfill. DO NOT overfill the gas tank. Allow at least 1/2" of empty space below the fill neck to allow for fuel expansion Heat / flames / sparks. Stay away from sources of heat, flame, or sparks while adding fuel. <div style="text-align: center; margin-top: 10px;">  </div>
5. Spills / splashes	<p>Clean up fuel spills /splashes immediately.</p> <ol style="list-style-type: none"> 1. Move log splitter away from spilled fuel on the ground. 2. Wipe fuel off engine and wait 5 minutes for excess fuel to evaporate before starting engine. 3. Gas soaked rags are flammable and should be disposed of properly. 4. If gasoline is spilled on your skin or clothes, change clothes and wash skin immediately.
6. Replace gas cap	<p>Replace gas cap securely before starting engine.</p>
7. Gasoline storage	<p>Store extra gasoline in a cool, dry place in an UL approved, tightly sealed container.</p>

Before Each Use – Work Site Selection & Set-Up

Step Three: Work site selection and log splitter set-up

WARNING

It is important to select an appropriate work site and properly set up the log splitter in order to minimize the risk of slips and falls, equipment rolling or tipping over, carbon monoxide poisoning, and accidental fires.

1. Select location	<p>Select an appropriate location for operating the log splitter.</p> <p><u>Requirements:</u></p> <ol style="list-style-type: none"> 1. Dry, level surface with good footing. Stay clear of areas with mud, ice, tall grass, weeds, or brush. 2. Outdoors, away from air intakes. <p> DANGER: The running engine gives off carbon monoxide, a poisonous gas that can kill you. You CANNOT smell it, see it, or taste it.</p> <ul style="list-style-type: none"> • ONLY run log splitter <u>OUTDOORS</u> and at least 20 feet from the home, away from windows, vents and air intakes, to allow proper ventilation. NEVER run log splitter inside homes, garages, sheds, or other buildings or semi-enclosed spaces. These spaces can trap poisonous gases, EVEN if you run a fan or open windows. • If you start to feel sick, dizzy, or weak while using the log splitter, shut off the engine and get to fresh air RIGHT AWAY. See a doctor. You may have carbon monoxide poisoning.
2. Fire precautions	<p>Take the following precautions against fire:</p> <ol style="list-style-type: none"> 1. <u>IMPORTANT:</u> If your splitter will be used near any unimproved forest, brush, or grassy covered land, <i>then engine must be equipped with a <u>spark arrestor.</u></i> 2. Make sure you comply with applicable local, state and federal codes. 3. Keep a fire extinguisher available (classified for both ordinary combustibles & flammable liquids) as a precautionary measure when operating the log splitter in dry areas.
3. Position 7' from any combustibles or flammable liquids	<p>Position splitter at least 7 ft. from combustible objects during operation.</p> <p>Hot exhaust fumes from splitter engine could cause fire. Also, hydraulic oil leaking or spraying on hot engine can ignite.</p>
4. Block Wheels	<p>Block wheels to prevent unintended movement of the log splitter.</p>

Splitting Operation



Before starting the log splitter, review the following instructions and safety information for safe operation. Failure to follow these rules may result in serious injury to the operator or bystanders from moving parts that crush, cut, or entangle; from flying objects, burns, fire, falling or tripping; or from carbon monoxide poisoning.

General safety information

- **Read manual.** Do not allow anyone to operate the log splitter who has not read the Owner's Manual or has not been instructed on the safe use of the splitter. The log splitter owner should instruct all operators in safe log splitter operation.
- **Age restrictions.** Never allow anyone under 16 years old to operate the log splitter. Children 16 years and older must be trained and supervised by a trained adult.
- **Intended use.** Log splitters should only be used for splitting wood logs, lengthwise with the grain. Do not use for other purposes as unforeseen hazards may result.
- **Modifications.** Never modify or alter the log splitter in any way. Modifications can create serious safety hazards and will void the warranty:
 - **Attachments.** Never add attachments to the splitter, except for authorized accessories supplied by the manufacturer with instructions for safe installation and use.
 - **Engine speed.** The maximum engine speed is preset at a safe limit. Never attempt to modify the engine speed setting to run at a higher speed.
 - **Fuel/exhaust system.** NEVER modify or add to the exhaust system, fuel tanks, or fuel lines. Fire can result.
 - **Remote control.** NEVER attach a rope, cable, or other remote device to the splitting control.
 - **Splitting wedge.** NEVER attempt to change the height or speed of the splitting wedge.
 - **Pressure setting.** NEVER increase the pressure setting of the pump or control valve.
- **Safety equipment / controls.** Always operate the log splitter with all safety equipment in place and in good working order, and all controls properly adjusted for safe operation.
- **Know how to stop.** Be thoroughly familiar with all controls and with the proper use of the equipment. Know how to stop the log splitter and relieve system pressures quickly if needed.
- **Operating speed.** Always operate the log splitter at the manufacturer's recommended speed. The maximum speed of the engine, pump and wedge are preset within safe limits.
- **Daylight only.** Only use the log splitter in daylight so you can see what you are doing.
- **Smoking / sparks.** Never smoke while operating the log splitter, and never operate near sources of sparks or flames.
- **Under the influence.** Never operate, or let anyone else operate, the log splitter while under the influence of alcohol, drugs, or medication.
- **Unattended.** Never leave the machine unattended while the engine is running.
- **Refueling.** Never refuel the engine until it has cooled at least two minutes.
- **Adjusting / repairing.** Always make sure the engine is off before cleaning, repairing or adjusting the splitter, except as recommended by the manufacturer. In addition, disconnect the spark plug and move all control handles back and forth to relieve system pressure *before changing or adjusting hydraulic system components* such as hoses, tubing, fittings or other components.
- **Replace labels.** Always make sure safety labels are in place and in good condition. If a safety label is missing or not legible, order new labels because unsafe operation can result. Call 1-800-817-1005 to order new safety labels.

Splitting Operation

1. Put on protective clothing / gear	<p>Wear the following protective clothing and safety gear.</p> <ol style="list-style-type: none"> 1) Eye protection. Always wear safety glasses or goggles when operating the machine. Pieces of log may fly out and serious eye injury can occur 2) Boots. Falling logs can crush feet. Always wear safety shoes or heavy boots when operating or helping to load logs. 3) Gloves. Wear snug fitting gloves without drawstrings or loose cuffs. 4) Hearing protection. The use of earplugs or other hearing protection device is recommended. 5) No Loose / dangling apparel. Loose or dangling apparel can become entangled in moving parts. Never wear jewelry or loose-fitting clothing
2. Lock & block	<p>Secure log splitter from unintended movement. Check that:</p> <ol style="list-style-type: none"> 1) The jack is locked in the DOWN position. 2) The wheels are blocked.
3. Start engine	<p>Start the engine. See the engine owner's manual for engine starting instructions.</p> <p><u>Note:</u></p> <ol style="list-style-type: none"> a) Make sure the hydraulic oil is above 10°F before starting the engine. Cold hydraulic oil can damage the hydraulic pump. b) If outdoor air temperature is below 32°F, allow log splitter to warm up by extending and returning the wedge several times before splitting wood. <p> WARNING:</p> <p>Burns. To avoid burns, stay clear of hot muffler if you are starting a warm engine.</p> <p>Carbon monoxide. The running engine gives off carbon monoxide, a poisonous gas that can kill you. You CANNOT smell it, see it, or taste it. If you start to feel sick, dizzy, or weak while using the log splitter, shut off the engine and get to fresh air RIGHT AWAY. See a doctor. You may have carbon monoxide poisoning.</p> <p>Other exhaust dangers. Engine exhaust, some of its constituents, and certain vehicle components contain or emit chemicals known to the State of California to cause cancer, birth defects, or other reproductive harm. Avoid inhalation of exhaust.</p>
4. Load log	<p>Load log onto beam between the wedge and an endplate, cut edge against the endplate - positioned for a lengthwise cut.</p> <p><u>Notes:</u></p> <ol style="list-style-type: none"> a) This log splitter is equipped with a unique double-edged cutting wedge, which is capable of splitting wood on either the extension or retraction stroke of the wedge. b) The log splitter is designed <u>only</u> for cutting lengthwise with the grain, NOT for cutting across the grain. c) This log splitter is designed for cutting logs only up to 24" long and 16" in diameter, lengthwise with the grain only. Larger diameter logs could get stuck on the wedge and longer logs will not fit on the beam.

Splitting Operation

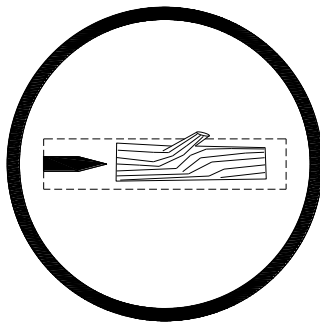

Correct
Log Orientation

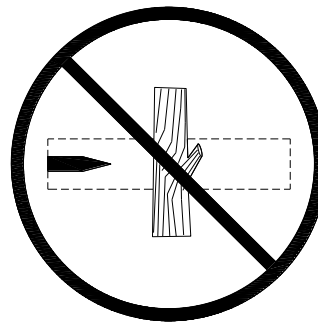

Incorrect
Log Orientation

FIG00216

⚠ WARNING: ALWAYS keep hands and feet away from the wedge and partially split logs while loading, operating and unloading the log splitter.

Important safety instructions:

- **Hold bark side.** Hold the bark side of logs when loading or positioning, never the ends. Never place your hands or any part of your body between a log and any part of the log splitter. NEVER place hands on log while splitting.
- **Wedge moving.** NEVER load or unload logs while the wedge is moving.
- **Straddling / reaching across.** Never straddle, reach across, or step over the beam while the engine is running. You could trip, actuate the controls, and get seriously injured.
- **Unsplit log pile.** Do not pile logs to be split in a place that will make you reach across the log splitter in order to load them.
- **Square log ends.** Logs that are not cut square can slide out while splitting and become a safety hazard or cause excessive force to log splitter components. Use a chainsaw to cut logs square on each end before attempting to split them.
- **Single log.** Never attempt to split more than one log at a time. Pieces of log can unexpectedly be thrown from the machine causing serious injury.
- **Split along grain.** Do not use the log splitter to split logs across the grain. Doing so will damage the log splitter and could also cause pieces of log to be thrown, injuring the operator or bystanders.
- **Forked logs.** Splitting forked logs can cause damage to the log splitter. Trim the forked log with a chain saw prior to splitting the log.

Splitting Operation

5. Extend wedge

Move Split Control Lever toward the end plate to move the wedge and split the log.

SPLIT CONTROL

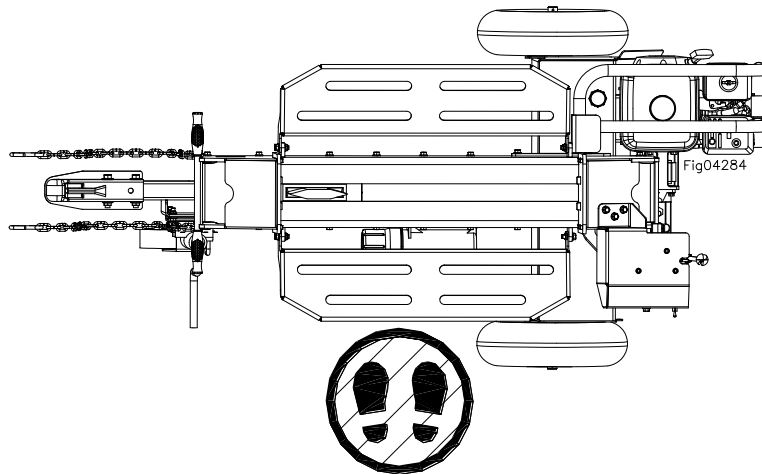
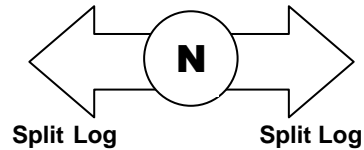

Operator Position

Important safety instructions:

- **Operator position.** ALWAYS operate the log splitter from the manufacturer's indicated OPERATOR POSITION. (See diagram above.) Other positions are unsafe because they can increase the risk of injury from crushing, cutting, flying objects, or burns.
- **Remove hands.** Remove both hands from log before activating the split control lever.
- **Hand activate.** Use only your hand to operate the Split Control Lever. Never use any other body part, or a rope, cable, or other remote device to actuate the control.
- **Second person.** Many accidents occur when there is more than one person involved in loading and operating the log splitter. Only one person should operate the controls. *If a second person is assisting in loading logs, the operator must NEVER actuate the split control lever until the assistant and all bystanders are at least 10 feet away. NEVER allow an assistant to hold the log in place while the operator actuates the Split Control Lever.*

Splitting Operation

6. Stop wedge

Release Split Control Lever to stop wedge movement when log is split.

⚠️ WARNING: Cracks in logs can close quickly and pinch fingers. Keep fingers away from any cracks that open in partially split logs.

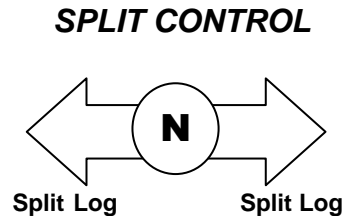

7. Important STUCK LOG procedure

If a log does not split completely and becomes stuck on the wedge, follow the instructions below to remove the log.

A log can become stuck to the wedge if the wedge becomes embedded in the log and the log doesn't split and separate. This can happen if the log is too stringy or tough to split completely.

If this happens, follow the directions below.

⚠️ WARNING: NEVER attempt to remove a stuck log by:

- Using the hydraulic force of the splitter
- Modifying the splitter
- Adding attachments to the splitter

Personal injury could result from log or metal pieces flying out at high speed toward the operator or bystanders, or the splitter could become damaged.

1. Remove pressure from log by moving wedge away from the endplate.
2. Turn engine OFF.
3. Remove stuck log from the wedge **manually** with a pry bar or a sledgehammer.
Important: Be extremely careful as log pieces may fly off as they separate from the wedge. Make sure bystanders are clear and wear safety goggles.
4. Do not attempt to re-split a stuck log once it has been removed from the wedge. Manually split with an axe or cut with a chainsaw.

8. Remove split wood

Move each log away from log splitter after it is split. Split logs left near the log splitter are a trip hazard.

9. After use

1. Turn off engine.

2. Remove engine debris.

Debris on a hot engine can be a fire hazard. After the engine is off, clean debris and chaff from engine cylinder head, cylinder head fins, blower housing rotating screen, and muffler areas.

⚠️ WARNING: Avoid contact with hot muffler.

Any Questions, Comments, Problems or Parts Orders
Call Iron & Oak Product Support 1-800-817-1005

Specifications

Maximum Pressure	3000 PSI
Maximum Flow	11 GPM
Hydraulic Fluid Capacity.....	12 Gallons
Hydraulic Fluid Type.....	*10 wt AW32, ASLE H-150, or ISO32
Engine Size.....	160 cc
Coupler Size.....	2"
Maximum Towing Speed.....	45 MPH
Maximum Log Length	24"
Maximum Log Diameter	16"
Pressure Relief Setting	3000 PSI
Hydraulic Cylinder Bore	4"
Hydraulic Cylinder Stroke	24"
Spark Arrestor.....	No
Fuel Valve.....	Yes
Overall Dimensions	77"L x 39"W x 46"H
Dry Weight	607 lbs

* If the log splitter will be run for long periods of time in outdoor temperatures above 70°F, we recommend changing the hydraulic oil to DEXTRON III

The manufacturer reserves the right to make improvements in design and/or changes in specifications at any time without incurring any obligation to install them on units previously sold.

Any Questions, Comments, Problems or Parts Orders
Call Iron & Oak Product Support 1-800-817-1005

Summary of Important Safety Information for Operation



WARNING

Carefully read and make sure you understand the following safety information before using the log splitter.

Improper use or maintenance of the log splitter can result in serious injury to the operator or bystanders from moving parts that can crush or cut, flying objects, escaping high pressure hydraulic fluid, or carbon monoxide poisoning.

Introduction

- **Read manual.** Read this Operator's Manual and the engine Owner's Manual completely before attempting to use the log splitter. Serious injury or death can result if safety instructions are not followed.
- **Instruct operators.** The log splitter owner should instruct all operators in safe log splitter operation.
- **Intended use.** Log splitters should only be used for splitting wood logs, lengthwise with the grain. Do not use for other purposes, as unforeseen hazards may result.

Prohibition Against Modifications

Never modify or alter the log splitter in any way. Modifications can create serious safety hazards and will void the warranty.

- **Attachments.** Never add attachments to the splitter, except for authorized accessories supplied by the manufacturer with instructions for safe installation and use.
- **Engine speed.** The maximum engine speed is preset at a safe limit. Never attempt to modify the engine speed setting to run at a higher speed.
- **Fuel/exhaust system.** NEVER modify or add to the exhaust system, fuel tanks, or fuel lines. Fire can result.
- **Remote control.** NEVER attach a rope, cable, or other remote device to the splitting control.
- **Splitting wedge.** NEVER attempt to change the height or speed of the splitting wedge.
- **Pressure setting.** NEVER increase the pressure setting of the pump or control valve.

Operator Restrictions

- **Untrained operators.** Do not allow anyone to operate the log splitter who has not read the Owner's Manual or been instructed on the safe use of the splitter.
- **Minimum operator age.** Never allow anyone under 16 years old to operate the log splitter. Children 16 years and older must be trained and supervised by a trained adult.

Safety in Moving and Towing the Log Splitter



WARNING

The log splitter is very heavy. It can crush and cause serious injury if it rolls out of control or tips over.

Follow the instructions below for safely moving and towing the log splitter.

General Safety While Moving

- **Hills.** Do not move the log splitter up or down hills by hand -- use a towing vehicle.
- **Engine off.** Never move the log splitter with its engine running.
- **No riding.** Never allow anyone to sit or ride on the log splitter.
- **No cargo.** Never transport cargo or wood on the log splitter.

Summary of Important Safety Information for Operation

Safety During Towing

- **Read instructions.** Review towing safety instructions in your towing vehicle manual.
- **Securely attached.** Be sure the log splitter is securely attached to the towing vehicle before towing.
- **Tires.** Be sure tires are fully inflated and in good repair before towing the splitter. When adding air to tires, do not over-inflate -- serious injury could occur if tire explodes.
- **Added length.** Be aware of the added length of the splitter.
- **Speed limit.** Never tow this log splitter over **45** mph. Faster speeds may result in loss of control.
- **Rough terrain.** Be extra cautious and drive slowly when traveling over rough terrain.
- **Under the influence.** Never tow this splitter while under the influence of alcohol, drugs, or medication.
- **On public roads.** If towing on a public road, make sure to comply with all local, state, and federal towing requirements. It is the sole responsibility of the purchaser to obtain licensing, trailer lights, safety chains or signage, as needed to comply.
- **Unattended.** Turn off the towing vehicle before leaving the splitter unattended.
- **Disconnect before operate.** Do not use the log splitter while it is connected to the towing vehicle.

Safety – Before Use

Read/instruct

- **Read manual.** Do not allow anyone to operate the log splitter who has not read the Owner's Manual or has not been instructed on the safe use of the splitter.
- **Review safety rules.** Before starting this log splitter, review the instructions for safe operation. Failure to follow these instructions may result in serious injury to the operator or bystanders.
- **Know how to stop.** Be thoroughly familiar with all controls and with the proper use of the equipment. Know how to stop the log splitter and relieve system pressure quickly if needed.

Personal protective equipment

- **Eye protection.** Always wear ANSI Z87.1 approved safety glasses or goggles when operating the machine. Pieces of log may fly out and serious eye injury can occur.
- **Boots.** Falling logs can crush feet. Always wear safety shoes or heavy boots when operating or helping to load logs.
- **Loose / dangling.** Loose or dangling apparel can become entangled in moving parts. Never wear jewelry or loose-fitting clothing.
- **Gloves.** Wear snug fitting gloves without drawstrings or loose cuffs.
- **Hearing protection.** The use of earplugs or other hearing protection device is recommended.

Safety During Inspection/Maintenance

Always inspect your log splitter before each use, and repair as needed, to keep it in safe working condition:

- **Engine off.** Always make sure the engine is off before cleaning, repairing or adjusting the splitter, except as recommended by the manufacturer.
- **Engine debris.** Debris on a hot engine can be a fire hazard. With the engine off, clean debris and chaff from engine cylinder head, cylinder head fins, blower housing rotating screen, and muffler areas. Avoid contact with hot muffler.
- **Other debris.** Debris on moving parts can cause excess wear. With the splitter engine off, clear debris from moving parts.
- **Fuel tank / lines.** Before each use, check fuel tank and fuel lines for leaks. Any fuel leak is a fire hazard. Fix any fuel leaks before starting engine.
- **Mechanical parts.** Check to be sure all nuts and bolts are tight to make sure the log splitter is in safe working condition.
- **Hydraulic system.** Check the hydraulic system (hoses, tubing, clamps/fittings, pump, and cylinder) carefully before each use. Do not operate the log splitter with frayed, kinked, cracked or damaged hydraulic hoses, fittings, or tubing, or if oily residue is observed on any of the components. High fluid pressures and temperatures are developed in the log splitter. Hydraulic fluid escaping through a pin hole sized opening can burn or puncture skin, resulting in wounds that could cause blood poisoning, infection, disability, gangrene, amputation, or death. Therefore, the following instructions should be heeded at all times when inspecting or servicing the hydraulic

Summary of Important Safety Information for Operation

components of the log splitter:

- Do not remove the hydraulic oil fill cap when the engine is running. Hot oil can escape causing severe burns. Allow log splitter to cool completely before removing hydraulic oil fill cap.
- Do not adjust the pressure setting of the pump or valve.
- Do not check for leaks with your hand. Leaks can be located by holding a piece of cardboard or wood (at least two feet long) with your hand at one end and passing the other end over the suspected area (wear eye protection). Look for discoloration of the cardboard or wood.
- Stop the engine, disconnect the spark plug, and move split control lever back and forth to relieve pressure before changing or adjusting hydraulic system components such as hoses, tubing, fittings or other components.
- If injured by escaping fluid, no matter how small the wound is, see a doctor at once. A typical injection injury may be a small puncture wound that does not look serious. However, severe infection or reaction can result if proper medical treatment is not administered immediately by a doctor who is familiar with injection injuries.
- **Spark arrestor muffler.** If the engine is equipped with a spark arrestor muffler, clean and inspect it regularly (follow manufacturer's service instructions). Replace if damaged.
- **Tires.** Be sure tires are fully inflated and in good repair before towing the splitter. When adding air to tires, do not over-inflate -- serious injury could occur if tire explodes.
- **Guards / shields.** Make sure all guards and shields are replaced after servicing the log splitter.
- **Replacement parts.** If a part needs replacement, only use parts that meet the manufacturer's specifications. Replacement parts that do not meet specifications may result in a safety hazard or poor operation of the log splitter.

Safety During Fueling

- **Gasoline is highly flammable and explosive.** You can be burned or seriously injured when handling fuel. Use extreme care when handling gasoline:
- **Fuel outdoors.** Fill fuel tank outdoors – never indoors. Gasoline vapors can ignite if they collect inside an enclosure. Explosion can result.
- **Use approved container.** Never pump fuel directly into engine at gas station. Static charge can build and ignite fuel. Use an UL approved fuel container to transfer gas to the engine.
- **Running / hot engine.** A running engine is hot enough to ignite fuel. Never add fuel or remove gas cap if engine is running or still hot. Stop the engine and allow it to cool, at least two minutes before adding fuel.
- **Heat / flames / sparks.** Stay away from sources of heat, flame, or sparks while adding fuel.
- **Don't overfill.** DO NOT overfill the gas tank. Allow at least 1/2" of empty space below the fill neck to allow for fuel expansion.
- **Replace cap.** Replace gas cap securely before starting engine.
- **Spills.** Clean up fuel spills immediately. Move log splitter away from spilled fuel on the ground. Wipe fuel off engine and wait 5 minutes for excess fuel to evaporate before starting engine. Gas soaked rags should be disposed of properly.
- **On skin / clothes.** If gasoline is spilled on your skin or clothes, change clothes and wash skin immediately.
- **Gasoline storage.** Store gasoline in a cool, dry place in an UL approved, tightly sealed container.

Safety in Work Site Selection / Set-up

- **Spark arrestor.** If your splitter will be used near any unimproved forest, brush, or grassy covered land, then engine should be equipped with a spark arrestor. See the "Specifications" section of this manual to determine if your splitter already has a spark arrestor. Make sure you comply with applicable local, state and federal codes.
- **Hot exhaust.** Hot exhaust fumes from engine can cause fire. Position muffler at least 7' from combustible objects during operation.
- **Fire extinguisher.** Have a Class ABC fire extinguisher available as a precautionary measure when operating the log splitter in dry areas.
- **Level, dry surface.** To prevent accidental falls and equipment tip over, make sure the splitter is situated on a dry, level surface with good footing. Stay clear of areas with mud, ice, tall grass, weeds, or brush.
- **Block wheels.** Always block the wheels to prevent unintended movement of the log splitter.

Summary of Important Safety Information for Operation

- Carbon monoxide. The running engine gives off carbon monoxide, a poisonous gas that can kill you. You CANNOT smell it, see it, or taste it. ONLY run log splitter OUTDOORS and at least 20 feet from the home, away from windows, vents and air intakes, to allow proper ventilation. NEVER run log splitter inside homes, garages, sheds, or other semi-enclosed spaces. These spaces can trap poisonous gases, EVEN if you run a fan or open windows. If you start to feel sick, dizzy, or weak while using the log splitter, shut off the engine and get to fresh air RIGHT AWAY. See a doctor. You may have carbon monoxide poisoning.

Safety – During Use

General Safety During Use

⚠ WARNING: Before starting this log splitter, review the following rules for safe operation. Failure to follow these rules may result in serious injury to the operator or bystanders.

- **Safety equipment / controls.** Always operate the log splitter with all safety equipment in place and in good working order, and all controls properly adjusted for safe operation.
- **Operating speed.** Always operate the log splitter at the manufacturer's recommended speed. The maximum speed of the engine, pump and wedge are preset within safe limits.
- **Know how to stop.** Be thoroughly familiar with all controls and with the proper use of the equipment. Know how to stop the log splitter and relieve system pressures quickly if needed.
- **Daylight only.** Only use the log splitter in daylight so you can see what you are doing.
- **Smoking / sparks.** Never smoke while operating the log splitter, and never operate near sources of sparks or flames.
- **Hot muffler.** If you are starting a warm engine, stay clear of muffler. It may still be hot enough to burn you.
- **Unattended.** Never leave the machine unattended while the engine is running.
- **Under the influence.** Never operate, or let anyone else operate, the log splitter while under the influence of alcohol, drugs, or medication.
- **Adjusting repairing.** Always make sure the engine is off before cleaning, repairing or adjusting the splitter, except as recommended by the manufacturer. In addition, disconnect the spark plug and move all control handles back and forth to relieve system pressure *before changing or adjusting hydraulic system components* such as hoses, tubing, fittings or other components.
- **Carbon monoxide.** The running engine gives off carbon monoxide, a poisonous gas that can kill you. You CANNOT smell it, see it, or taste it. If you start to feel sick, dizzy, or weak while using the log splitter, shut off the engine and get to fresh air RIGHT AWAY. See a doctor. You may have carbon monoxide poisoning.
- **Other exhaust dangers.** Engine exhaust, some of its constituents, and certain vehicle components contain or emit chemicals known to the State of California to cause cancer, birth defects, or other reproductive harm. Avoid inhalation of exhaust.

Safety in Loading, Operating, and Unloading

- **Square log ends.** Logs that are not cut square can slide out while splitting and become a safety hazard or cause excessive force to log splitter components. Use a chainsaw to cut logs square on each end before attempting to split them.
- **Single log.** Never attempt to split more than one log at a time. Pieces of log can unexpectedly be thrown from the machine causing serious injury.
- **Split along grain.** Do not use the log splitter to split logs across the grain. Doing so will damage the log splitter and could also cause pieces of log to be thrown, injuring the operator or bystanders.
- **Forked logs.** Splitting forked logs can cause damage the log splitter. Trim the forked log with a chain saw prior to splitting the log.
- **Keep hands clear.** ALWAYS keep hands and feet away from the end plate, wedge, and partially split logs while loading, operating and unloading the log splitter.
- **Operator position.** ALWAYS operate the log splitter from the manufacturer's indicated OPERATOR POSITION. Other positions are unsafe because they can increase the risk of injury from crushing, cutting, flying objects, or burns.
- **Straddling / reaching across.** Never straddle, reach across, or step over the beam while the splitter engine is running. You could trip, actuate the controls, and get seriously injured.
- **Second person.** Many accidents occur when there is more than one person involved in loading and operating the log splitter. Only one person should operate the controls. *If a second person is assisting in loading logs, the operator must NEVER actuate the Split Control Lever until the assistant and all bystanders are at least 10 feet away. NEVER allow an assistant to hold the log in place while the operator actuates the Split Control Lever.*

Summary of Important Safety Information for Operation

Loading/Unloading

- **Unsplit log pile.** Do not pile logs to be split in a place that will make you reach across the log splitter in order to load them.
- **Hold bark side.** Hold the bark side of logs when loading or positioning, never the ends. Never place your hands or any part of your body between a log and any part of the log splitter.
- **Wedge moving.** NEVER load or unload logs while the wedge is moving.
- **Cracks.** Cracks in logs can close quickly and pinch fingers. Keep fingers away from any cracks that open in partially split logs.
- **Split log pile.** Move each log away from log splitter after it is split. Split logs left near the log splitter are a trip hazard.
- **Remove hands.** Remove both hands from log before activating Split Control Lever.
- **Hand activate.** Use only your hand to operate the Split Control Lever. Never use any other body part, or a rope, cable, or other remote device to actuate the control.
- **Log stuck on wedge.** A log can become stuck to the wedge if the wedge becomes embedded in the log and the log doesn't split and separate. This can happen if the log is too stringy or tough to split completely. If this happens, follow the directions below to manually remove the log:
 - **IMPORTANT:** NEVER attempt to remove a stuck log by using the hydraulic force of the splitter, or by modifying or adding attachments to splitter. Personal injury could result from log or metal pieces flying out at high speed toward the operator or bystanders, or the splitter could become damaged.
 - 1. Remove pressure from log by moving wedge away from the endplate.
 - 2. Turn engine OFF.
 - 3. Remove stuck log from the wedge **manually** with a pry bar or a sledgehammer. Be extremely careful, as log pieces may fly off as they separate from the wedge. Wear safety goggles and make sure bystanders are clear.
 - 4. Do not attempt to re-split a stuck log once it has been removed from the wedge.
- **Refueling.** Never refuel the engine until it has cooled at least two minutes.

Safety – After use

- **Remove engine debris.** Debris on a hot engine can be a fire hazard. With the engine off, clean debris and chaff from engine cylinder head, cylinder head fins, blower housing rotating screen, and muffler areas. Avoid contact with hot muffler.
- **Let engine cool before storing.** Let engine cool for at least five minutes before storing. A hot engine can be a fire hazard.
- **Storage location.** Store the log splitter in a location away from sources of heat, open flames, sparks or pilot lights – such as water heaters, space heaters, furnaces, clothes dryers, or other gas appliances. Even if the log splitter's gas tank is empty, residual gasoline vapors could ignite.
- **Gasoline storage.** Store extra gasoline in a cool, dry place in an UL approved, tightly sealed container. Gasoline vapors can ignite if they collect inside an enclosure.
- **Periodic maintenance.** Perform periodic maintenance as directed in this manual to keep the log splitter in safe working condition.

This page has intentionally been left blank.



Great Northern Equipment Distributing Inc.
20195 S. Diamond Lake Rd, Ste 100
Rogers, MN 55374
Assembled in USA